

(1) **EU-Type Examination Certificate**
according to Module B Paragraph 6.1 of PPE Regulation (EU) 2016/425

- (2) Regulation of the European Parliament and of the Council of 9 March 2016 relating to personal protective equipment (PPE) - Regulation (EU) 2016/425
- (3) No. of EU-Type Examination Certificate: **ZP/B147/19**
- (4) Product: **Anchor device type B, type: LUX-top® QUICKFIX II**
- (5) Manufacturer: **ST QUADRAT Fall Protection S.A.**
11, rue Flaxweiler, 6776 GREVENMACHER / POTASCHBERG, LUXEMBURG
- (6) Address: **ST QUADRAT Fall Protection S.A.**
45, rue Fuert, 5410 BEYREN, LUXEMBURG
- (7) Risk category: **III**
- (8) The design and construction of this personal protective equipment and any acceptable variation thereto are specified in the appendix to this EU type-examination certificate.
- (9) The certification body of DEKRA Testing and Certification GmbH, Notified Body No. 0158 according to Chapter V of Regulation (EU) 2016/425 of 9 March 2016, certifies that this personal protective equipment has been found to comply with the essential Health and Safety Requirements given in Annex II to the Regulation. The evaluation results are recorded in report PB 19-016. Other possibly applicable Union legislations applicable to the specified personal protective equipment have not been taken into account in this EU-type examination certificate.
- (10) The essential Health and Safety Requirements are assured in consideration of
DIN EN 795:2012 **DIN CEN/TS 16415:2017**
- (11) This EU type-examination certificate relates only to the design, examination and tests of the specified personal protective equipment in accordance to Regulation (EU) 2016/425.
For category III personal protective equipment, this EU type-examination certificate may only be used in conjunction with one of the conformity assessment procedures referred to Article 19 (c).
- (12) When applying the CE Marking according to Article 16 and 17 of Regulation (EU) 2016/425 to the products that conform to the types examined, the client is obliged to add, in accordance with the attached pattern, the identification number of the Notified Body engaged in the conformity assessment according to Module C2 or D.
Furthermore, the manufacturer is obliged to issue an EU declaration of conformity in accordance with Article 15 of Regulation (EU) 2016/425 and to enclose it with the personal protective equipment, or to indicate the Internet address in the manual and in the instructions in Annex II, point 1.4., at which the EU declaration of conformity can be accessed.
- (13) This EU-Type Examination Certificate is valid until 2024-06-24.

DEKRA Testing and Certification GmbH
Bochum, 2019-06-25

Signed: Kilisch
Managing director

We confirm the correctness of the translation from the German original. In the case of arbitration only
the German wording shall be valid and binding.

Managing director

TRANSLATION

- (14) Appendix to
- (15) **EU-Type Examination Certificate**
ZP/B147/19
- (16) 16.1 Subject and type
Anchor device type B
Type: LUX-top® QUICKFIX II

16.2 Description

The anchor device, type: LUX-top® QUICKFIX II serves as a temporary single anchor point to protect a maximum of three persons against falls from a height (fig. 1).

The anchor device consists of two beam clamps ($t = 4 \text{ mm}$) that are freely displaceable on the threaded rod (M16) and can be locked by means of nuts.

The maximum clamping width is 200 mm. At one end there is an eyelet holder ($t = 6 \text{ mm}$) with a ring eyelet M16. This eyelet serves to accommodate the personal protective equipment against falls from a height. The fixation on the building is being realized by tensioning the anchor device by means of the hex nuts on the two beam clamps. The anchor device is intended for loads exerted from any direction and consists of corrosion resistant steel.

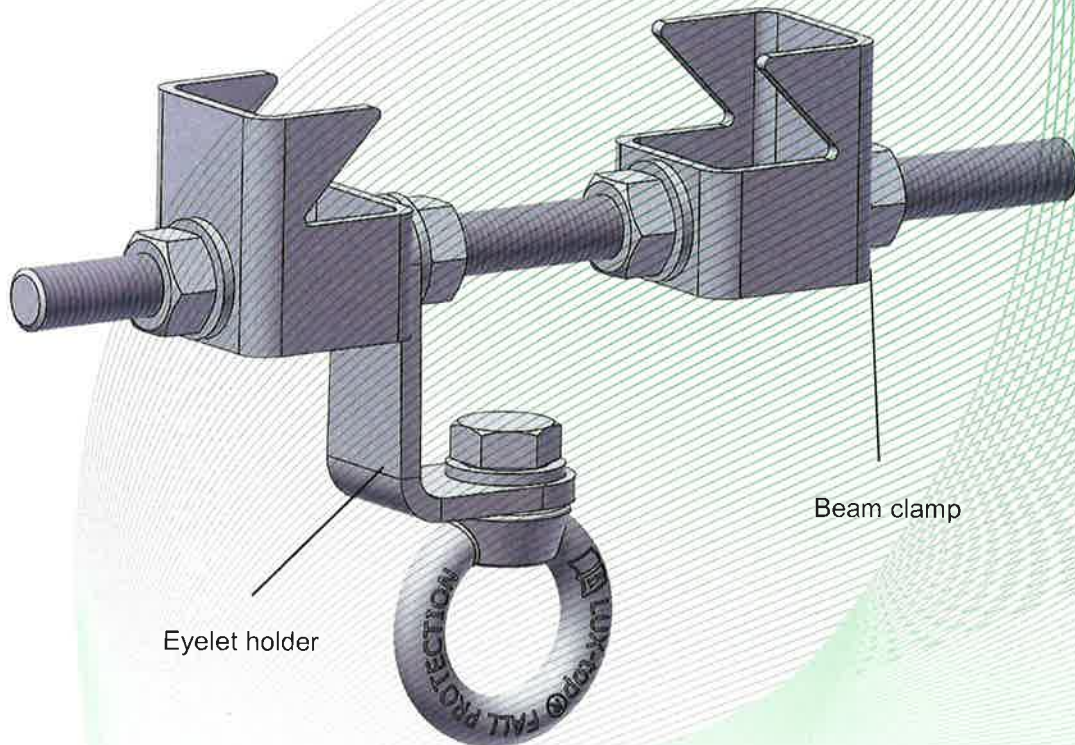

Fig. 1: Anchor device, type: LUX-top® QUICKFIX II

- (17) Report

PB 19-016, 2019-06-25